

# POMPA PER VUOTO LUBRIFICATA A PALETTE OIL-LUBRICATED ROTARY VANE VACUUM PUMP

## 102PBO-M



Gruppo pompante in ghisa accoppiato al motore elettrico tramite giunto elastico. Separatore aria/olio in alluminio per l'eliminazione di nebbie d'olio in mandata, valvola di ritegno in aspirazione, raffreddamento ad aria, filtro olio.

Cast iron pumping unit coupled to the electric motor via a flexible coupling. Aluminium oil/air separator eliminates oil mist discharge, suction check valve, air cooling, oil filter.

**Accessori** : Filtro aria, valvola zavorra gas, vacuometro, Fluido sintetico atossico BGS TORR F100®  
**Tensioni speciali** : UL-CSA

**Accessories** : Air filter, gas ballast valve, vacuum gauge, BGS TORR F100® non-toxic synthetic fluid  
**Special voltages**: UL-CSA

## SPECIFICHE / SPECIFICATIONS

(I) (F)	(GB) (E)		PBO		PBOM	
			50Hz	60Hz	50Hz	60Hz
Portata nominale Débit nominal	Nominal capacity Caudal nominal	m <sup>3</sup> /h *	100	120	100	120
Pressione finale (ass.) Presión final (abs.)	Ultimate pressure (abs.) Vide final (abs.)	mbar * hPa *	10		0,5	
Potenza motore Puissance moteur	Motor power Potencia motor	Kw - 3 ~	2,2	3,0	2,2	3,0
		Kw - 1 ~	--	--	--	--
Numero di giri Número de révolutions	Revolutions number Velocidad de giro	min. <sup>-1</sup>	1.450	1.740	1.450	1.740
Max pres. di asp. per vapore H2O Pression max. d'entrée pour la vapeur d'eau	Max inlet pressure for water vapour Presión máx. admisible del vapor de agua	mbar hPa	30	30	30	30
Max q.tà vapore d'acqua Débit de pompage max de vapeur d'eau	Max water vapour pumping rate Cantidad máx. vapor de agua	Kg/h	2	2	2	2
Livello di pressione acustica Niveau de pression acoustique	Sound pressure level Nivel de presión acústica	dB(A)*	73	75	73	75
Carica olio Charge d'huile	Oil charge Carga de aceite	L	5,8			
Peso totale Poids total	Total weight Peso total	Kg	82	86	82	86

\* = tolleranza / tolerance / tolérance / tolerancia ±10%



**BGS GENERAL srl**  
Via Zibido, 3 - 20080 Zibido San Giacomo (MI) - Italy  
+39 02.90005069 r.a. - bigiesse@bigiesse.it - www.bigiesse.it

E0\_R0

# POMPA PER VUOTO LUBRIFICATA A PALETTE OIL-LUBRICATED ROTARY VANE VACUUM PUMP

# 3D

## 102PBO-M

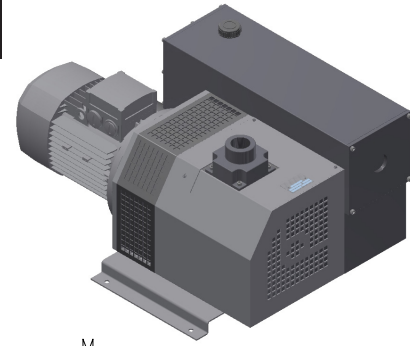

### DIMENSIONI / DIMENSIONS

	mm
A*	707
B*	366
C	437
D	278
E	115
F	118
G	225
H	350
K	268
L	164
M	444
N	112
O	115
P	164
R	64
Øa	1"1/4G
Øm	1"1/4G
Øf	10
X	231
Y	472
W	30

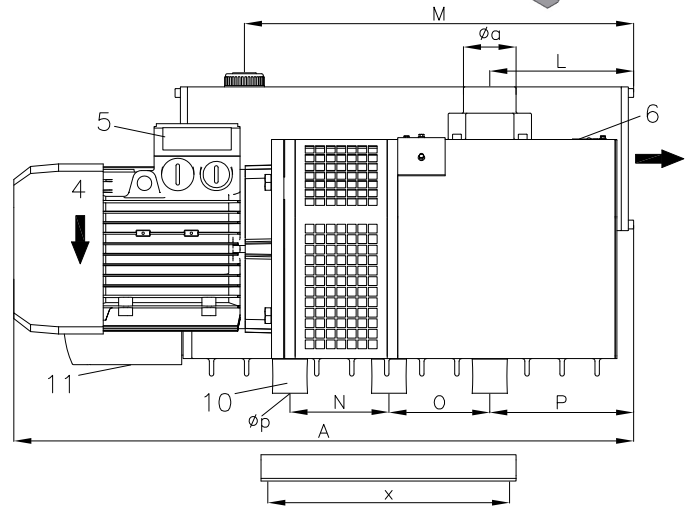
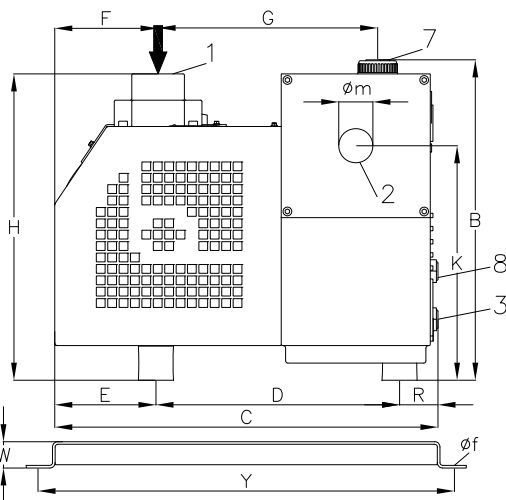

1	Valvola di aspirazione	Suction valve	5	Morsetteria	Wiring box
2	Scarico aria	Exhaust	6	Targhetta dati	Data plate
3	Scarico olio	Oil drain	7	Tappo riempimento olio	Oil filler
4	Freccia senso di marcia	Rotation arrow	8	Spia livello olio	Oil control

\* = Le quote A e H possono subire variazioni / The dimensions A and H as well as the current drawn can differ - Salvo modifiche tecniche / We reserve the right to alter technical information

### PRESTAZIONI / PERFORMANCE CURVE

PBO

PBOM

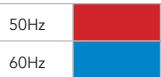
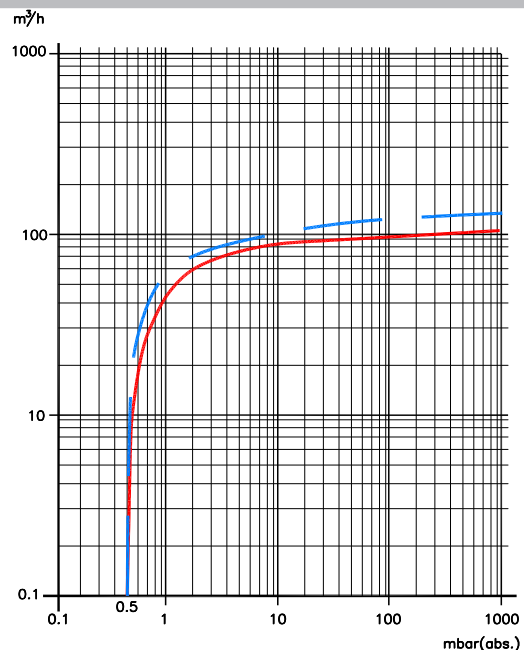
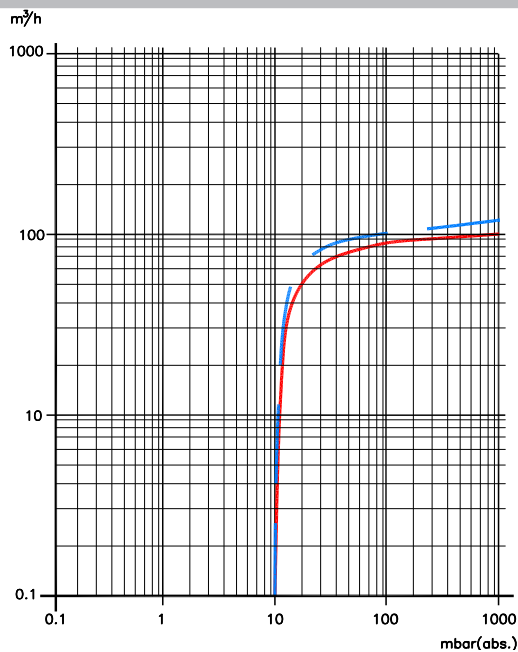

Curve riferite alla pressione di aspirazione e temp. 20°C (tolleranza ±10%). / Curves refers to inlet pressure and 20°C temp. (tolerance ±10%).

**BGS GENERAL srl**

Via Zibido, 3 - 20080 Zibido San Giacomo (MI)

+39 02.90005069 r.a. - bigiesse@bigiesse.it - www.bigiesse.it



E0\_R0